

The DEETER Group®

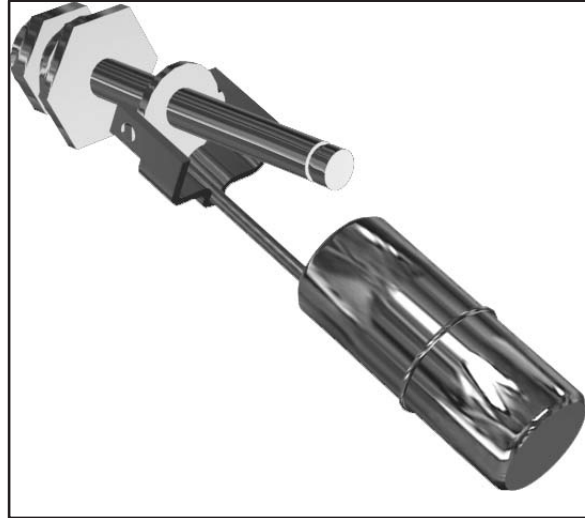

80 SERIES HORIZONTAL STAINLESS STEEL LIQUID LEVEL SENSOR

Small horizontally mounted liquid level sensor designed for high temperature/high pressure operation and sensing chemically aggressive liquids. The design provides a highly cost effective solution where high reliability in a demanding environment is called for.



DEL80-	
10 - 10W Form C	
50 - 50W Form A	
A - Form A	
C - Form C	
01 - M16 Internal Mount	
02 - 3/4" NPT External Mount	

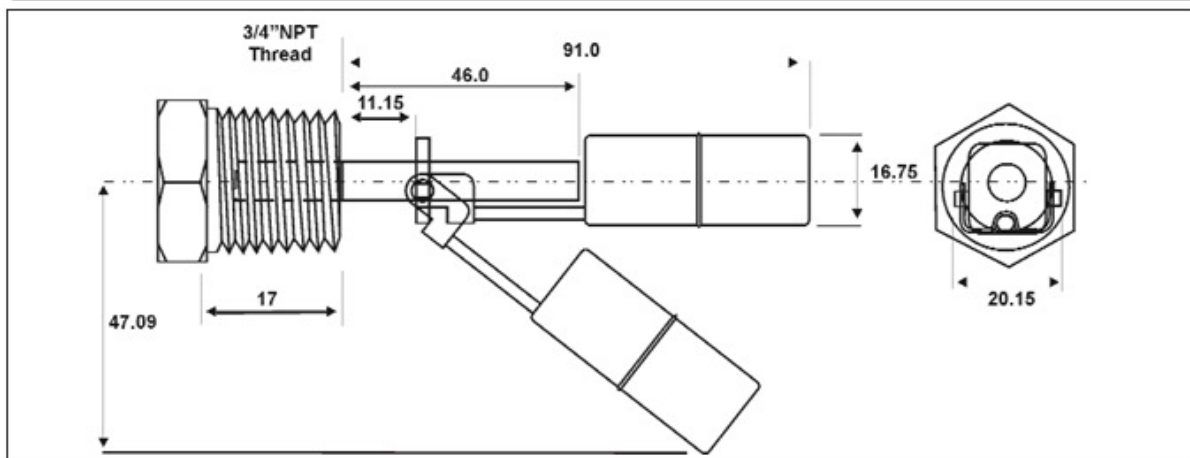
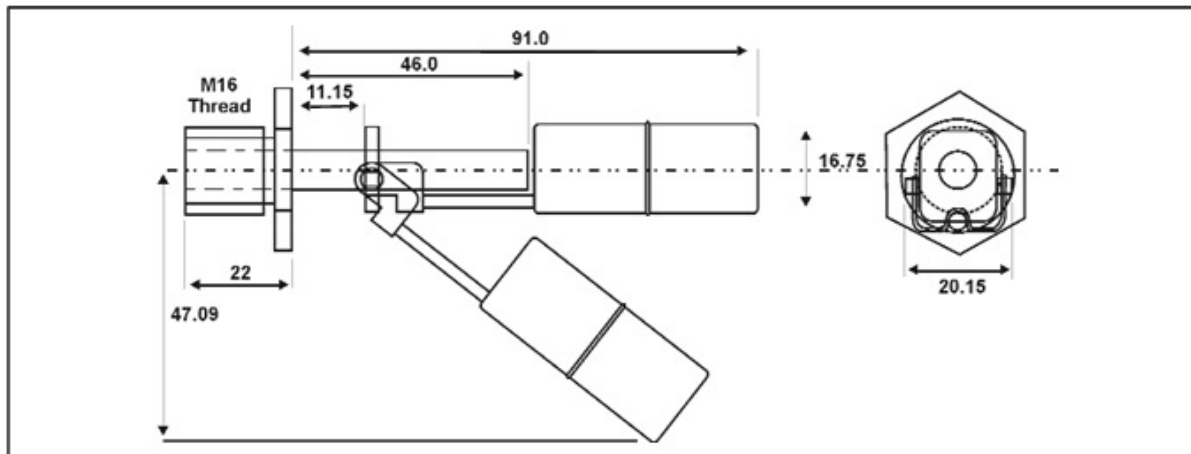

All electrical equipment should be installed by a qualified electrician.

DEETER ELECTRONICS LTD

Deeter House, Valley Road, Hughenden Valley, Bucks. HP14 4LW
UK. Tel: 44 (0)1494 566 046 Fax: 44 (0)1494 563 961
Email: sales@deeter.co.uk Website www.deeter.co.uk

Distributed by:

The **DEETER** Group®



80 SERIES HORIZONTAL STAINLESS STEEL LIQUID LEVEL SENSOR

Technical Data	
Switch contact rating (pure resistive load). For other loads ie. capacitive, inductive or incandescent lamps) please contact Deeter for advice.	50 Watts max. Form A SPST Contacts 250vAC max. switching voltage 1.0 Amps max. switching current 10 Watts max. Form C SPDT Contacts 60v DC max. switching voltage 200v DC breakdown voltage 1A max switching
Cable Type Cable Length Operating Pressure Specific Gravity of Float Mounting detail Maximum tank wall thickness Wetted materials Weight	PTFE Insulated 7/0.2mm rated to 200°C max. 1 metre 500 p.s.i.(3,445 kPa) 0.9 M16 or 3/4"NPT for external mount option 8mm (internal mount only) 316L Stainless Steel 80g

All electrical equipment should be installed by a qualified electrician.

DEETER ELECTRONICS LTD

Deeter House, Valley Road, Hughenden Valley, Bucks. HP14 4LW
UK. Tel: 44 (0)1494 566 046 Fax: 44 (0)1494 563 961
Email: sales@deeter.co.uk Website www.deeter.co.uk

Distributed by: